



Item Name: 7816-3LED

YYB Code: PDT.CP_76

Power: 1.5W

Voltage: DC12V

Size: 78*16*10mm

Colour: Cool White White Warm White
Red Green Blue Yellow Pink

Design Features

- High Quality 2835SMD LED mounted, golden wire with copper base;
- Constant voltage circuit for flexible cut of the module string;
- Double Layer fiber glass PCB with 1.6mm thickness, heat well distributed;
- Optical lens of 160 degree angle with even light project to cover board surface;
- Maximum module quantity per string up to 20pcs;
- Center distance between nearby LED module is 201mm.

CONSTRUCTION

7816-3LED

LED Lamp : Triple-Die chip, 2835 sized

Lens and Body : PC Lens 93% transparency, ABS Housing

PCB : FR-4 _Fiber glass epoxy resin, double-layered

Wire Thickness: 18 AWG

Wires Length: 123mm

Max connection : 50pcs for one connection in serial

Safety Rank: IP65Prevents water & dust penetration

Fix Assistance: 3M adhesive tapes and M2.5 screwing hole

SPECIFICATION**7816-3LED**

OPTICAL Viewing Angle: 160°
 Color Rendering Index(CRI): 85Ra
 Optical Attenuation: 0.5%

THERMAL Cooling : Ambient air
 Maximum operating temperature : 40°C
 Minimum operating temperature : -20°C
 Maximum storage temperature : 60°C
 Minimum storage temperature : -25 C

APPLICATION Channel letters;
 Storefront lighting;
 Sign board;
 Border lighting;
 Show case signage;
 Other commercial lighting and signage.

PACKING Anti-static bag: 100modules(20.7meter,68feet)
 Carton box : 3000modules(30bags, 621meter,
 2040feet)

OPTOELECTRONIC PARAMETERS

LED Color	Color Temperature(K) Wavelength (NM)	Luminous Flux (lm/piece)	Power (W)	Luminous Intensity
Cold White	8000-9500K	130-135lm	1.5W	120lm/w
White	6000-6500K	130-135lm	1.5W	120lm/w
Warm White	3000K	130-135lm	1.5W	120lm/w
Red	620-625nm	2700-3000MCD/LEDs	1.2W	2800MCD/w
Green	520-530nm	5000-5600MCDLEDs	1.5W	4200MCD/w
Blue	455-465nm	4200-4700MCDLEDs	1.5W	3500MCD/w

*Data are based on Ta at 25°C.

*Product spec are accurate at time of published. Information is subjected to change without prior notice. (Dec 2019)

PHYSICAL DIMENSION

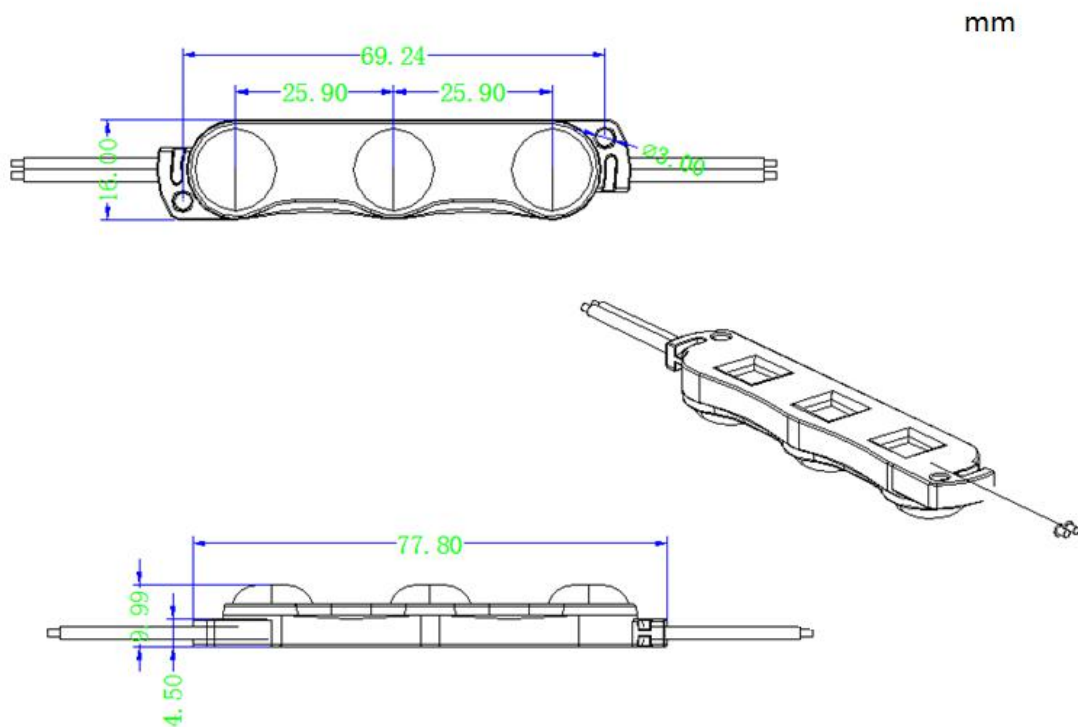

INSTALLATION INSTRUCTION

- Clean the touch surface of the object before pasting the modules onto the surface.
- Peel off the PE tape from the adhesive foam of the back side of modules, prefix the modules on the object by adhesive foam, adjust the modules place and distance as per actual need.
- Inject glass sealant or mount the modules on object with screws for Permanent fix.

Tips:

- Single module as a unit can be cut off from the module string according to the project actual needed.
- Wires conductor have to seal/cover by insulator completely in case of short circuit or electric spark.
- Max quantity of one circuit can support 50pcs modules by electricity reinforce, over this quantity the voltage drop down phenomenon will be obvious revealed and significantly increased which will severely impact the light effect of the modules.